

TOYOTA COROLLA HATCH

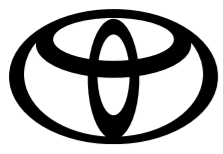

HAS IT ALL



Issued on: 2025/02/25



SPECIFICATIONS

Corolla HB 1.8 XS HEV

Corolla HB 2.0 XR

Corolla HB 2.0 XR BT

Corolla HB 1.8 XR HEV

Corolla HB 1.8 XR HEV BT

Engine and Drivetrain

| | | | | | |
|---|-------------------|-----------------|-----------------|-------------------|-------------------|
| A/T Oil Temp Warning | | • | • | | |
| Bore x Stroke (mm) | 80.5 x 88.3 | 80.5x97.6 | 80.5x97.6 | 80.5x88.3 | 80.5x88.3 |
| Fuel System | Petrol Hybrid SFI | Petrol SFI | Petrol SFI | Petrol Hybrid SFI | Petrol Hybrid SFI |
| Maximum Power (kW @ r/min) | 72 @ 5200 | 125 @ 6600 | 125 @ 6600 | 72 @ 5200 | 72 @ 5200 |
| Maximum Torque (Nm @ r/min) | 142 @ 3600 | 202 @ 4600-5000 | 202 @ 4600-5000 | 142 @ 3600 | 142 @ 3600 |
| Number of Cylinders and Arrangement | Inline-4 | Inline-4 | Inline-4 | Inline-4 | Inline-4 |
| Total System Output (kW) | 103 | | | 103 | 103 |
| Engine capacity (litre) | 1.8 | 2.0 | 2.0 | 1.8 | 1.8 |
| Fuel Consumption (Combined Cycle) (l/100km) | 4.0 | 6.0 | 6.0 | 4.0 | 4.0 |
| C02 Emission (g/km) | 91 | 137 | 137 | 91 | 91 |

Transmission

| | | | | | |
|-----------------|------------|------------|------------|------------|------------|
| Transmission | CVT | CVT | CVT | CVT | CVT |
| Driven Wheels | FWD | FWD | FWD | FWD | FWD |
| Starting System | Push Start | Push Start | Push Start | Push Start | Push Start |
| Paddle Shift | | • | • | | |

Suspension

| | | | | | |
|-------|-----------------|-----------------|-----------------|-----------------|-----------------|
| Front | MacPherson | MacPherson | MacPherson | MacPherson | MacPherson |
| Rear | Double-Wishbone | Double-Wishbone | Double-Wishbone | Double-Wishbone | Double-Wishbone |

Wheels and Tyres

| | | | | | |
|-------------|--|--|--|--|--|
| Spare Wheel | Full 205-55R16 Alloy | Space Saver 125-70D17 | Space Saver 125-70D17 | Space Saver 125-70D17 | Space Saver 125-70D17 |
| Tyre Size | F:205-55R16 Alloy R:205-55R16 Alloy | F:225-40R18 Alloy R:225-40R18 Alloy | F:225-40R18 Alloy R:225-40R18 Alloy | F:225-40R18 Alloy R:225-40R18 Alloy | F:225-40R18 Alloy R:225-40R18 Alloy |

Body and Styling

| | | | | | |
|-----------------------|---|---|--|---|--|
| Body Colour | Monotone | Monotone | Two tone | Monotone | Two tone |
| Daytime Running Light | • | • | • | • | • |
| Door Outside Handles | Colour - Coded | Colour - Coded | Colour - Coded | Colour - Coded | Colour - Coded |
| Front Bumper | Colour Coded | Colour Coded | Colour Coded | Colour Coded | Colour Coded |
| Front Fog Lamps | • | • | • | • | • |
| Headlights | LED Auto High Beam | Bi-LED Auto High Beam | Bi-LED Auto High Beam | Bi-LED Auto High Beam | Bi-LED Auto High Beam |
| Headlamp Levelling | Standard Manual | Standard Manual | Standard Manual | Standard Manual | Standard Manual |
| Light Control System | Auto Light Control System, Follow me home | Auto Light Control System, Follow me home | Auto Light Control System, Follow me home | Auto Light Control System, Follow me home | Auto Light Control System, Follow me home |
| Side Mirrors | Colour Coded Power / Auto-Retractable / Blind Spot Monitor (BSM) / Heated | Colour Coded Power / Auto-Retractable / Blind Spot Monitor (BSM) / Heated | Black Power / Auto-Retractable / Blind Spot Monitor (BSM) / Heated | Colour Coded Power / Auto-Retractable / Blind Spot Monitor (BSM) / Heated | Black Power / Auto-Retractable / Blind Spot Monitor (BSM) / Heated |
| Rear Bumper | Colour Coded | Colour Coded | Colour Coded | Colour Coded | Colour Coded |
| Rear Lights | LED | LED | LED | LED | LED |
| Rear Fog Lamp | • | • | • | • | • |
| Front Window Wiper | Intermittent | Auto, Rainsensing | Auto, Rainsensing | Auto, Rainsensing | Auto, Rainsensing |

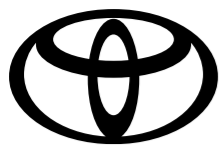

SPECIFICATIONS

Corolla HB 1.8 XS HEV

Corolla HB 2.0 XR

Corolla HB 2.0 XR BT

Corolla HB 1.8 XR HEV

Corolla HB 1.8 XR HEV BT

Body and Styling

| | | | | | |
|--------------|----------|----------|----------|----------|----------|
| Rear Spoiler | Standard | Standard | Standard | Standard | Standard |
|--------------|----------|----------|----------|----------|----------|

Interior, Comfort and Convenience

| | | | | | |
|------------------------------|--|--|--|--|--|
| Cupholders | Standard 2 | Standard 2 | Standard 2 | Standard 2 | Standard 2 |
| Floor Carpet Trim | Carpet With Heel Pad | Carpet With Heel Pad | Carpet With Heel Pad | Carpet With Heel Pad | Carpet With Heel Pad |
| Rear View Mirror | Day & Night | Electrochromatic (EC) | Electrochromatic (EC) | Electrochromatic (EC) | Electrochromatic (EC) |
| Meter Illumination Control | . | . | . | . | . |
| 2nd Row Seats | 60:40 | 60:40 | 60:40 | 60:40 | 60:40 |
| Seat Trim | Fabric | Leather + Suede | Leather + Suede | Leather + Suede | Leather + Suede |
| Shift Lever & Knob | Leather | Leather | Leather | Leather | Leather |
| Steering Wheel | 3 Spoke Urethane | 3 Spoke Leather | 3 Spoke Leather | 3 Spoke Leather | 3 Spoke Leather |
| Seat Back Pockets | Standard Passenger only | Standard Driver and Passenger | Standard Driver and Passenger | Standard Driver and Passenger | Standard Driver and Passenger |
| Front Personal Lamp | Standard LED | Standard LED | Standard LED | Standard LED | Standard LED |
| Cruise Control | Standard Adaptive, All Speed | Standard Adaptive, All Speed | Standard Adaptive, All Speed | Standard Adaptive, All Speed | Standard Adaptive, All Speed |
| Airconditioner | Auto Dual zone | Auto Dual zone | Auto Dual zone | Auto Dual zone | Auto Dual zone |
| Audio System | Toyota Display Audio, DAB | Toyota Display Audio, DAB | Toyota Display Audio, DAB | Toyota Display Audio, DAB | Toyota Display Audio, DAB |
| Reverse Camera | Display Audio | Display Audio | Display Audio | Display Audio | Display Audio |
| Bluetooth | . | . | . | . | . |
| Front Seat Adjustment | Driver & Passenger Manual | Driver & Passenger Manual | Driver & Passenger Manual | Driver & Passenger Manual | Driver & Passenger Manual |
| Front Seat Vertical Adjuster | Driver Manual | Driver Manual | Driver Manual | Driver Manual | Driver Manual |
| Light Remind Warning | Standard Buzzer & Autocut-off | Standard Buzzer & Autocut-off | Standard Buzzer & Autocut-off | Standard Buzzer & Autocut-off | Standard Buzzer & Autocut-off |
| Multi-Information Display | . | . | . | . | . |
| Navigation System | | Standard | Standard | Standard | Standard |
| Power Socket | Front - 12V | Front - 12V | Front - 12V | Front - 12V | Front - 12V |
| Power Steering | Electric / (EPS) | Electric / (EPS) | Electric / (EPS) | Electric / (EPS) | Electric / (EPS) |
| Electric Windows | All All One Touch | All All One Touch | All All One Touch | All All One Touch | All All One Touch |
| Rear Armrest | Standard 2 Cupholders | Standard 2 Cupholders | Standard 2 Cupholders | Standard 2 Cupholders | Standard 2 Cupholders |
| Seat Heater | | Standard Driver and Passenger only | Standard Driver and Passenger only | Standard Driver and Passenger only | Standard Driver and Passenger only |
| Seat Lumbar Support | | Power, Driver | Power, Driver | Power, Driver | Power, Driver |
| Speakers | Standard 6 | Standard 6 | Standard 6 | Standard 6 | Standard 6 |
| Steering Switches | Standard Audio, Telephone, Info Display, Voice Command, Adaptive Cruise Control, Lane Trace Assist | Standard Audio, Telephone, Info Display, Voice Command, Adaptive Cruise Control, Lane Trace Assist | Standard Audio, Telephone, Info Display, Voice Command, Adaptive Cruise Control, Lane Trace Assist | Standard Audio, Telephone, Info Display, Voice Command, Adaptive Cruise Control, Lane Trace Assist | Standard Audio, Telephone, Info Display, Voice Command, Adaptive Cruise Control, Lane Trace Assist |
| Sun Visor | Standard Lamp, Mirror with Cover | Standard Lamp, Mirror with Cover | Standard Lamp, Mirror with Cover | Standard Lamp, Mirror with Cover | Standard Lamp, Mirror with Cover |
| USB | Standard 4 | | | Standard 4 | Standard 4 |

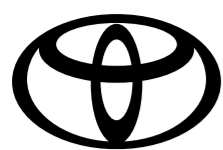

SPECIFICATIONS

Corolla HB 1.8 XS HEV

Corolla HB 2.0 XR

Corolla HB 2.0 XR BT

Corolla HB 1.8 XR HEV

Corolla HB 1.8 XR HEV BT

Interior, Comfort and Convenience

| | | | | | |
|------------------------------|-------------|-------------|-------------|-------------|-------------|
| Wireless Charger | | • | • | • | • |
| Android Auto & Apple CarPlay | • | • | • | • | • |
| Toyota Connect Enabled | • | • | • | • | • |
| USB Type | Type C 4PCs | Type C 4PCs | Type C 4PCs | Type C 4PCs | Type C 4PCs |

Safety and Security

| | | | | | |
|---------------------------------------|---|---|---|---|---|
| Anti-Theft System | Horn Alarm + Immobiliser | Siren Alarm + Immobiliser | Siren Alarm + Immobiliser | Siren Alarm + Immobiliser | Siren Alarm + Immobiliser |
| Child Lock | Standard Rear door | Standard Rear door | Standard Rear door | Standard Rear door | Standard Rear door |
| Child Restraint System (ISOFIX) | Standard 2 | Standard 2 | Standard 2 | Standard 2 | Standard 2 |
| Parking Brake | Electric | Electric | Electric | Electric | Electric |
| Front Brake | Ventilated Disc | Ventilated Disc | Ventilated Disc | Ventilated Disc | Ventilated Disc |
| Front Seat Belts | ELR, Pretensioner, Force Limiter | ELR, Pretensioner, Force Limiter | ELR, Pretensioner, Force Limiter | ELR, Pretensioner, Force Limiter | ELR, Pretensioner, Force Limiter |
| Power Door Lock | Standard | Standard | Standard | Standard | Standard |
| Pre-Crash System (Brake Synchronised) | • | • | • | • | • |
| Rear Brake | Disc | Disc | Disc | Disc | Disc |
| Rear Seat Belts | Standard ELR | Standard ELR | Standard ELR | Standard ELR | Standard ELR |
| Seat Belt Warning | Front + Rear Buzzer + Light | Front + Rear Buzzer + Light | Front + Rear Buzzer + Light | Front + Rear Buzzer + Light | Front + Rear Buzzer + Light |
| Wireless Door Lock | Standard Smart Entry | Standard Smart Entry | Standard Smart Entry | Standard Smart Entry | Standard Smart Entry |
| Airbags | Side, Curtain, Driver, Passenger, Driver Knee | Side, Curtain, Driver, Passenger, Driver Knee | Side, Curtain, Driver, Passenger, Driver Knee | Side, Curtain, Driver, Passenger, Driver Knee | Side, Curtain, Driver, Passenger, Driver Knee |
| Toyota Safety Sense | • | • | • | • | • |

Driver Support Systems

| | | | | | |
|---|----------------------------|--|--|--|--|
| Park Distance Control | | Standard Front + Rear, Intelligent Clearance Sonar | Standard Front + Rear, Intelligent Clearance Sonar | Standard Front + Rear, Intelligent Clearance Sonar | Standard Front + Rear, Intelligent Clearance Sonar |
| Anti-Lock Braking System (ABS) | • | • | • | • | • |
| Blind Spot Monitor (BSM) | • | Standard With Rear Cross Traffic Alert | Standard With Rear Cross Traffic Alert | Standard With Rear Cross Traffic Alert | Standard With Rear Cross Traffic Alert |
| Brake Assist (BA) | • | • | • | • | • |
| Electronic Brake Force Distribution (EBD) | • | • | • | • | • |
| Hill Assist Control (HAC) | • | • | • | • | • |
| Vehicle Stability Control (VSC) | • | • | • | • | • |
| Lane Keeping System | Standard Lane Trace Assist | Standard Lane Trace Assist | Standard Lane Trace Assist | Standard Lane Trace Assist | Standard Lane Trace Assist |

Service and Warranty

| | | | | | |
|-------------------------|-----------------------|-----------------------|-----------------------|-----------------------|-----------------------|
| Service Plan | 6 Services / 90,000km | 6 Services / 90,000km | 6 Services / 90,000km | 6 Services / 90,000km | 6 Services / 90,000km |
| Service Interval | 12 months / 15,000km | 12 months / 15,000km | 12 months / 15,000km | 12 months / 15,000km | 12 months / 15,000km |
| Warranty | 3 years / 100,000km | 3 years / 100,000km | 3 years / 100,000km | 3 years / 100,000km | 3 years / 100,000km |
| Hybrid Battery Warranty | 8 years 195,000km | | | 8 years 195,000km | 8 years 195,000km |

Dimensions and Capacities

| | | | | | |
|---------------------|-----|-----|-----|-----|-----|
| Front Overhang (mm) | 940 | 940 | 940 | 940 | 940 |
|---------------------|-----|-----|-----|-----|-----|

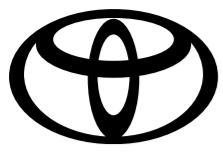

SPECIFICATIONS

Corolla HB 1.8 XS HEV

Corolla HB 2.0 XR

Corolla HB 2.0 XR BT

Corolla HB 1.8 XR HEV

Corolla HB 1.8 XR HEV BT

Dimensions and Capacities

| | | | | | |
|---------------------------------|------|------|------|------|------|
| Front Tread (mm) | 1530 | 1530 | 1530 | 1530 | 1530 |
| Fuel Tank Size (L) | 43 | 50 | 50 | 43 | 43 |
| Gross Combination Mass (GCM) | | 3145 | 3145 | | |
| Ground Clearance (mm) | 150 | 130 | 130 | 150 | 150 |
| Gross Vehicle Mass (GVM) | 1820 | 1845 | 1845 | 1820 | 1820 |
| Height (mm) | 1480 | 1460 | 1460 | 1480 | 1480 |
| Length (mm) | 4375 | 4375 | 4375 | 4375 | 4375 |
| Luggage Capacity (L) | 305 | 352 | 352 | 352 | 352 |
| Rear Overhang (mm) | 795 | 795 | 795 | 795 | 795 |
| Rear Tread (mm) | 1530 | 1530 | 1530 | 1530 | 1530 |
| Towing Capacity - Unbraked (kg) | | 450 | 450 | | |
| Towing Capacity - Braked (kg) | | 1300 | 1300 | | |
| Wheelbase (mm) | 2640 | 2640 | 2640 | 2640 | 2640 |
| Width (mm) | 1790 | 1790 | 1790 | 1790 | 1790 |
| Top Speed (km/h) | 180 | 210 | 210 | 180 | 180 |

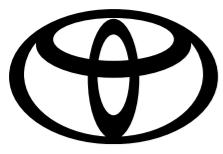

SPECIFICATIONS

LINE DRAWING

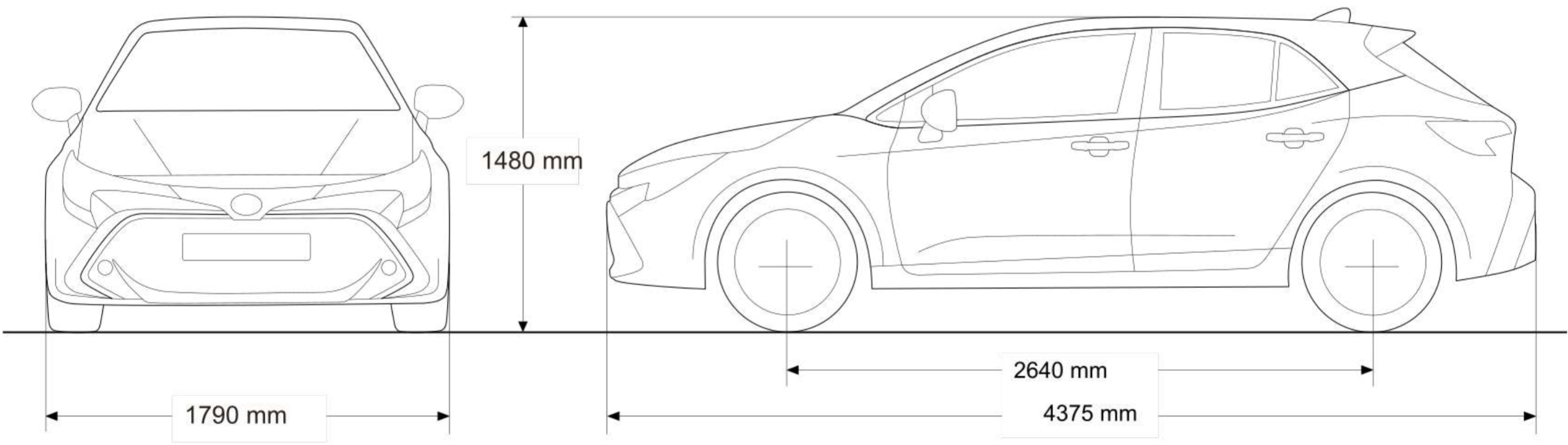

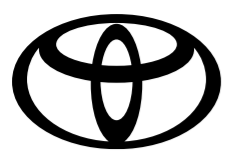

SPECIFICATIONS

EXTERIOR COLOURS

FOR ILLUSTRATIVE PURPOSES ONLY.

MONOTONE



040 - Glacier White



1F7 - Satin Silver
Metallic



089 - Platinum White
Pearl



1G3 - Graphite Grey
Metallic



4Y8 - Luminous Orange
Metallic



8W7 - Dark Blue Metallic

BI-TONE



2PS - Platinum White
Pearl Bitone



2UF - Satin Silver
Metallic Bitone



2XM - Vibrant Red
Bitone

**Disclaimer:**

The information contained within or made available on any Toyota platform or note including but not limited to, this website/brochure/specification sheet, is provided for information purposes only. While we make reasonable efforts to update the information on our platform/s, Toyota Motor Corporation of Japan, and Toyota South Africa Motors (Pty) Ltd makes no representations, warranties, or guarantees, whether express or implied, that the content is accurate, complete or up to date, and all information contained herein is subject to change without notice.

Vehicle specifications may vary depending on the model, trim level, and market. Colours depicted on print and web material may not match the actual vehicle colour. Fuel consumption figures are estimates based on standardised testing conditions and actual results may vary due to (but not limited to) driving style, vehicle loading, tyres, wind, traffic, and accessories. All dimensions, capacities, and performance figures are approximate. Some features/options may be optional or only available on certain models/trim levels. Images and illustrations are for illustrative purposes only and may not reflect the actual vehicle.

Your use of, or reliance on, any information or contents herein is entirely at your own risk. Toyota Motor Corporation of Japan and Toyota South Africa Motors (Pty) Ltd (including its owners, agents, consultants, employees, and any affiliated person(s)) are not responsible for any loss or damages related to your use of, reliance on, or understanding of any information or contents on this or any other Toyota platform. This includes, without limitation, any direct, indirect, special, incidental, consequential, or punitive damages in terms of any contract, delict (breach of a duty of care) or law.

Furthermore, Toyota Motor Corporation of Japan and Toyota South Africa Motors (Pty) Ltd do not guarantee the uninterrupted or error-free operation of any platform or the availability of content, and are not liable for any interruptions, errors, or damages caused by any technical issues or limitations of these platforms, including but not limited to, server downtime, software malfunctions, or internet connectivity issues.

